

DESIGN AND IMPLEMENTATION OF A HUMAN-FRIENDLY MULTI-TASK CLEANER ROBOT FOR ENHANCED EFFICIENCY IN INDUSTRIAL AND SERVICE APPLICATIONS

Ahmed A. Abdeltwab¹
Hanan M. Amer
Hala B. Nafea

Received 18.04.2025.
Revised 07.06.2025.
Accepted 16.07.2025.

Keywords:

Cleaner Robot, Multi-Functional Tasks, Sensors, PCB, ESP32, ATmega328.

Original research



ABSTRACT

The rapid advancement of robotics and automation technologies has revolutionized various aspects of our daily lives. Among these innovations, the Multi-Functional Cleaner Robot stands out as a remarkable solution for enhancing efficiency and versatility in household maintenance. In our project, our aim is to design Multi-Functional Cleaner Robot to perform a wide range of cleaning tasks, eliminating the need for multiple specialized devices. Equipped with advanced sensors and intelligent algorithms, it possesses the ability to navigate through diverse surfaces, and execute cleaning operations with precision. The robot's compact size and maneuverability enable it to access hard-to-reach areas, such as under furniture or in tight corners, ensuring a thorough cleaning experience.

Furthermore, the Multi-Functional Cleaner Robot incorporates advanced safety features to ensure smooth operation and protect both the robot and its surroundings. It utilizes obstacle detection sensors, collision avoidance algorithms, and anti-fall mechanisms to navigate safely within the environment, avoiding potential hazards and minimizing accidental damage.

© 2026 Journal of Innovations in Business and Industry

1. INTRODUCTION

The function of a multifunctional cleaner robot is to clean various surfaces and area in a home or other environment, providing a more comprehensive and efficient cleaning solution than traditional cleaning methods (Kim et al., 2019). The analysis of a multifunctional cleaner robot involves evaluating its performance, efficiency, and effectiveness in cleaning various surfaces and areas (Bisht et al., 2022; Murdan & Ramkissoon, 2020; Soni, 2017; Wang et al. 2023; Yan et al., 2020). This can include assessing its ability to navigate around obstacles, its battery life, and its overall design and functionality (Chang et al., 2018; Moon et al. 2022; Pathmakumar et al., 2021; Yan et al., 2020). Additionally, the analysis may involve comparing the robot to traditional cleaning methods or other robotic cleaners on the market to

determine its relative advantages and disadvantages (Butaney et al., 2025; Khaleel & Oleiwi, 2024).

1-1 Multi-Functional Cleaner Robot offers several key benefits:

- **Versatility:** With its interchangeable cleaning modules, the Cleaner Robot can perform a variety of cleaning tasks (Prassler et al., 2000).
- **Efficiency:** The Cleaner Robot is equipped with smart navigation technology that allows it to map and navigate complex environments (Zhao et al., 2016).
- **Safety:** The Cleaner Robot can detect and avoid obstacles, reducing the risk of damage to furniture or the robot itself (Vasic & Billard, 2013).
- **Ease of Use:** The Cleaner Robot can be easily controlled via a smartphone app, monitor the cleaning progress, and even manually control the robot if

¹ Corresponding author: Ahmed A. Abdeltwab
Email: hihamadaali2001@gmail.com

necessary (Sinnapatchai et al., 2022).

- Time-Saving: By automating the cleaning process, the Cleaner Robot saves users a significant amount of time, freeing them up to focus on other tasks (Said et al., 2024).
- Improved Hygiene: The Cleaner Robot's ability to disinfect surfaces to a healthier living or working environment by reducing the presence of bacteria and viruses (Boyce, 2016).

In summary, the history of multifunctional cleaner robots is characterized by continuous innovation and development, with companies focusing on enhancing the efficiency, autonomy, and functionality of their products (Prassler et al., 2000). The integration of smart home technology with robotic cleaners is a recent trend that is expected to continue shaping the industry.

1.2 Cleaner Robot History

Table 1 brings overview of cleaner robot history.

Table 1. Cleaner robot history

Year	Concept	Definition	Function
2012	Pool Cleaning (Junior et al., 2014).	Robots specifically designed to clean swimming pools.	Cleaning and maintaining swimming pools..
2017	Multi-Surface Adaptability (Yatmono et al. 2019)	Robots equipped with sensors and mechanisms to automatically adjust cleaning methods based on the type of surface being cleaned	Adapting to different floor types (hardwood, tile, carpet) and optimizing cleaning performance
2020	Advanced Obstacle Detection (Ivanov & Webster, 2017)	Integration of advanced sensors and algorithms to detect and avoid obstacles, preventing collisions and damage to the robot and surrounding objects.	Navigating around furniture, walls, and other obstacles without causing disruptions or accidents.
2022	Modular Attachments (Kim et al. 2019)	The ability to add or interchange specialized modules or accessories to expand the robot's cleaning capabilities, such as window cleaning.	Performing additional cleaning functions beyond vacuuming, such as window cleaning.
2024	Intelligent Mapping Robot (Ajeil et al., 2020)	Robots equipped with advanced mapping capabilities to create detailed floor plans	Creating accurate floor maps and recharging to ensure continuous cleaning operations.

2. METHODOLOGY

The process of building a multifunctional cleaner robot was never an easy task, since it's known that in such

projects your real task isn't perfection, but it's more of challenging to make the cleaner with multifunctional capabilities. The robot's frame is constructed from high-strength, lightweight composite materials, offering durability and ease of movement.

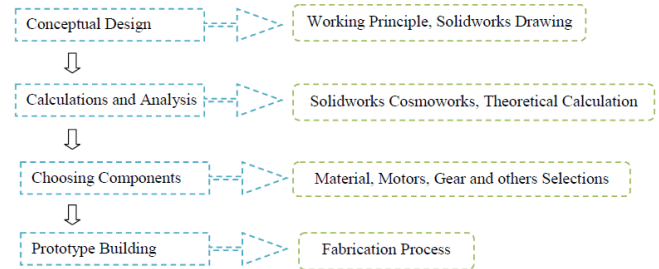

Figure 1. Flowchart of Robot Stages

Its body is designed with a low-profile, aerodynamic shape to facilitate movement under furniture and tight spaces, reducing drag and improving battery efficiency. Flowchart of Robot Stages is presented on the figure 1.

2.1 Mechanical design work

Overview of our parts:

- **Body Design:**
 - **The Multi-Functional Cleaner Robot (MFCR)'s body** as shown in figure 1 is constructed from a lightweight and durable material, such as ABS plastic. This material balances weight for maneuverability with the sturdiness to avoid damage during operation.
 - **The cylindrical body shape** allows for easy movement around furniture and tight corners as shown in figure 2a and figure 2b.
 - **Wheels:** Two large driving wheels on the rear provide traction and movement. An omnidirectional caster wheel in the front allows for smooth multidirectional maneuvering as shown in figure 3, figure 4 and figure 5.
 - **Sensors:** Several sensors are strategically placed on the body as shown in figure 6.
 - **The robot's mobility and cleaning mechanisms** are driven by a combination of motors and actuators as shown in figure 7 and figure 8.
 - **Stand for motor:** as shown in figure 9.
- **Brush System:** A rotating main brush agitates dirt and debris on the floor surface as shown in figure 10. The brush can be made of nylon bristles for hard surfaces or softer materials for delicate floors. Side brushes located on the left and right sides of the robot help sweep dirt and debris from corners and edges towards the main brush as shown in figure 11. The brush compartment should be easily accessible for brush removal and cleaning to maintain optimal performance.
- There are two wipers in front of robot that are for mopping, and erasing as shown in figure 12.

- Three faucets in their tanks are used for spraying, one of them is spraying water, the other is spraying sterilization, and the third is spraying polishing as shown in figure 13.
- There are two fans in the middle of robot that are for drying as shown in figure 14.
- There is a magnet so that it picks up metal objects, such as coins, or a chain.
- In the middle of the robot, there is a place for storage. The dirt that we removed collects in a place.
- The cleaning cycles will be all automatic, running on tracks and manual also

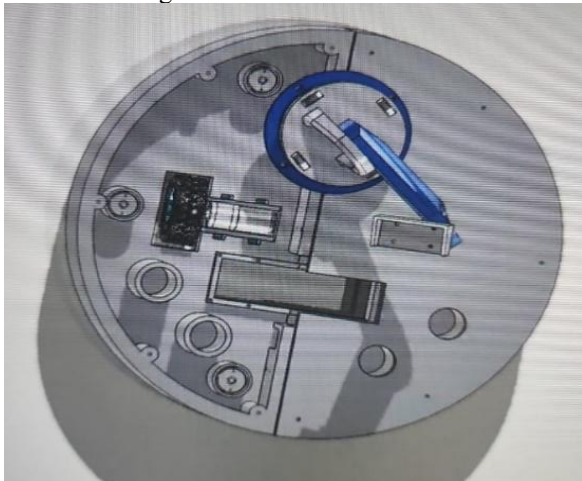

Figure 1. MFCR's body

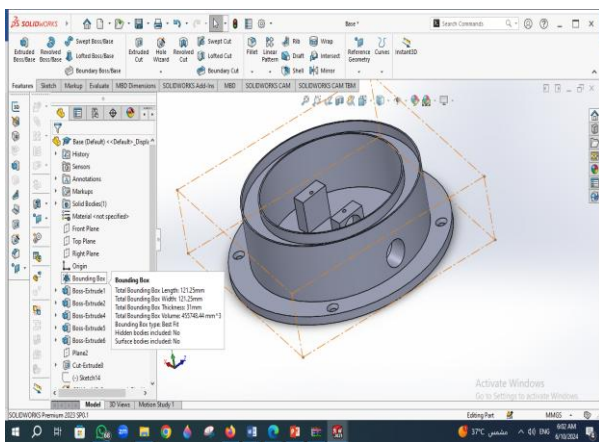

Figure 2a. Cylindrical body shape

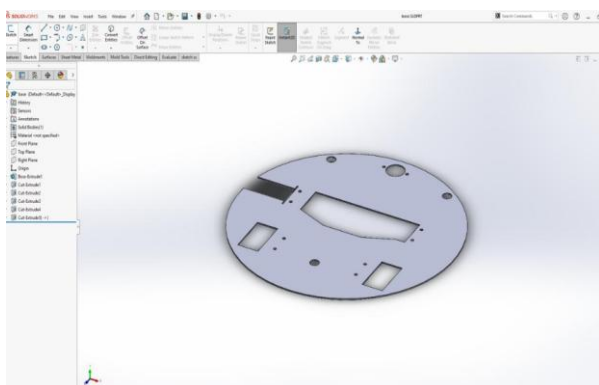

Figure 2b. The Base

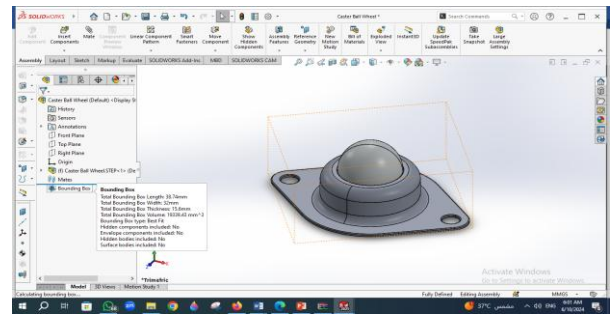

Figure 3. 360 cluster ball wheel Caster ball wheel



Figure 4. Fixed wheels

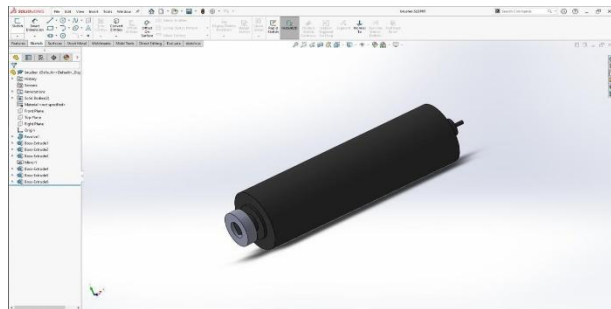

Figure 5. Brusher

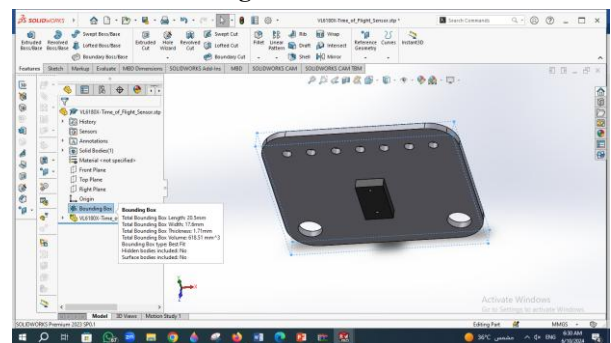

Figure 6. Flight sensor

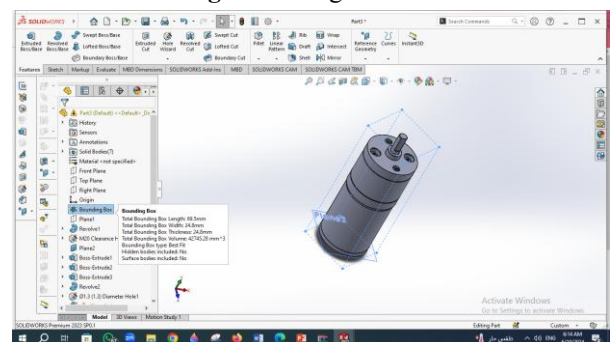

Figure 7. Dc geared motor

Design And Implementation of a Human-Friendly Multi-Task Cleaner Robot For Enhanced Efficiency in Industrial and Service Applications

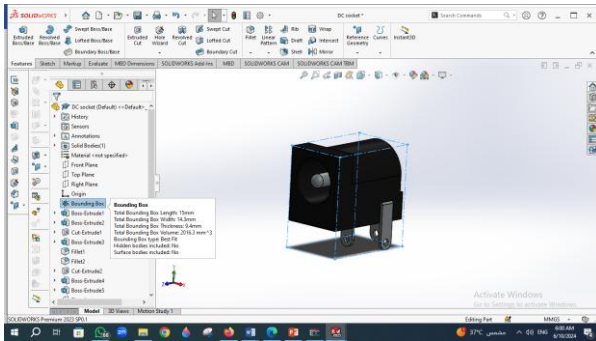

Figure 8. Dc socket

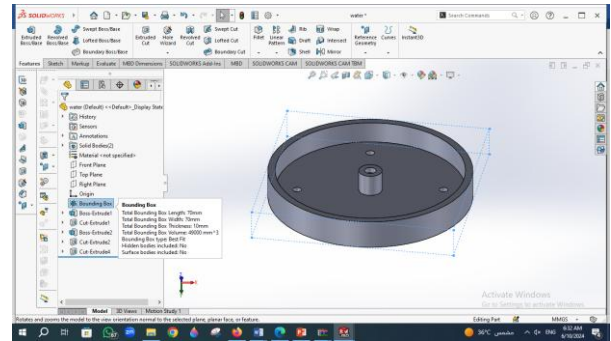

Figure 13. Water tanks

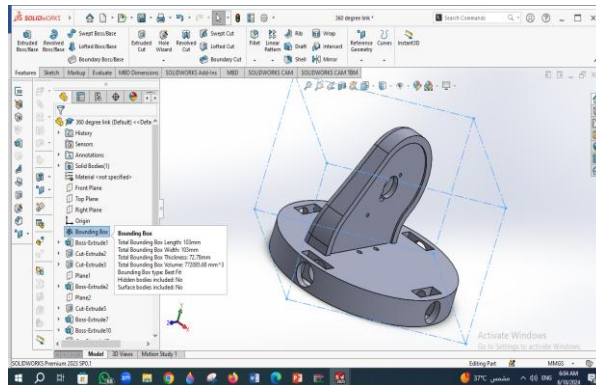

Figure 10. Bounding box

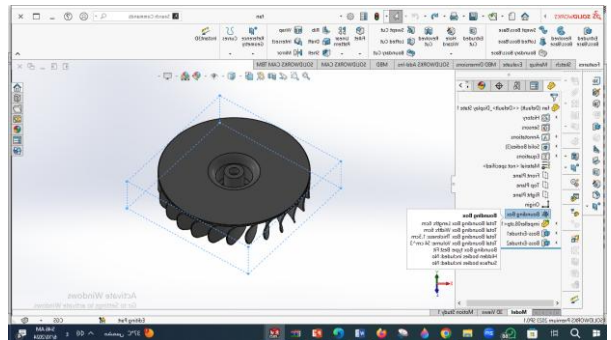

Figure 14. Fan

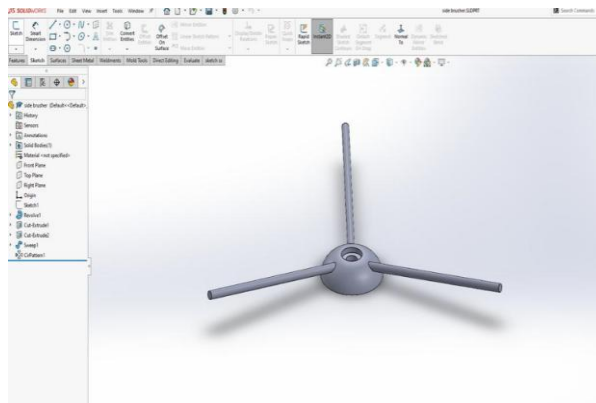

Figure 11. 360 degree link

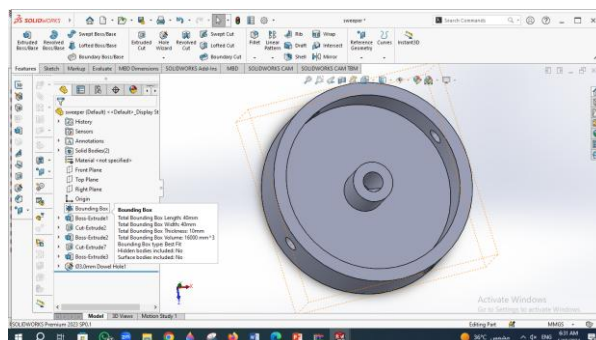

Figure 12. Sweeper (mopping)

2.2 Hardware and circuit design:

The Multi-Functional Cleaner Robot is a complex piece of technology that combines various hardware components to perform its cleaning tasks. Each component plays a crucial role in the operation of the robot, from the microcontroller that controls its functions, to the motor that drives its movements, to the sensors that help it navigate its environment. This will explore the key hardware elements that enable the robot to navigate, clean, and operate autonomously.

Overview of work

The device has:

- 6 motors for fans, wipers(mopping), and vacuums
- Motors moves forward and backward
- robot has 3 joints, uses 3 servos and can bear a high weight
- 5 sensors identify obstacles
- 2 sensors determine the space underneath 3 liquid pumps and four tanks
- The control will be semi-automatic, with parts that it will do on its own and parts that will take care of the web interface that will not be affected at all by the internet or the network.
- Magnets that pick up metals
- A hole in the middle has something like a fan that pulls dirt up and gets removed through a small bag

2.2.1 Cleaning Mechanisms:

- **Brushes:** These are likely powered by motors controlled by the microcontroller (ATmega328). Adjusting speed and direction

would require motor drivers and possibly encoders to track rotation.

- **Suction System:** A motor and filter system powered by the microcontroller. Likely, you'll want PWM (Pulse Width Modulation) control for adjusting suction power.
- **Mopping System:** Controlled by a water pump and mop pads, where the water tank and pump are managed based on the robot's cleaning schedule.

2.2.2 Power Management:

- **Battery:** Rechargeable battery, likely Li-ion or Li-poly. You'll need a charging circuit and power management ICs to ensure safe charging and long battery life.
- **Autonomous Charging:** The ESP32 or ATmega328 will help the robot navigate back to the charging dock when battery is low. A charging dock with a pin alignment mechanism could be useful here.

2.2.3 Connectivity:

- **Wi-Fi/Bluetooth (ESP32):** You'll probably use the ESP32 to handle wireless communication. With its dual-mode Bluetooth and Wi-Fi, users could control the robot through an app, schedule cleanings, and receive notifications.

2.2.4 Sensors:

- **VL6180X Distance Sensor:** This sensor will help with obstacle detection and navigation. Its high precision and narrow beam make it suitable for detecting nearby objects, helping the robot avoid collisions.

2.2.5 Relay Module:

- **Four-Channel Relay Module:** Useful for controlling high-power components like the motors for the brushes, suction, and mopping system. You can trigger the relays via the microcontroller to activate/deactivate different systems.

2.2.6 ESP32 and PCB Design:

- **ESP32:** The ESP32 will handle all connectivity and possibly some of the sensor data processing. It's perfect for real-time data streaming, like sending sensor info to the mobile app.
- **PCB Design:** It looks like you've also been designing your PCB for efficient interconnection of all these components. The PCB will need to route power, ground, communication lines, and sensor signals effectively.

2-7 Power Considerations:

- **Low Power Design:** Since it's a mobile robot, battery life is important. The ESP32 and ATmega328 are good choices due to their low power consumption when idle, but careful management of sensors and motors is essential to maximize efficiency

ESP32 vacuum board is presented on figure 15 and AVR vacuum board on figure 16.

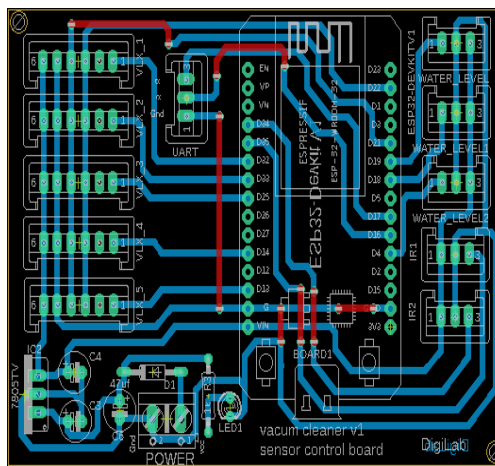

Figure 15. ESP32_vacuum_board

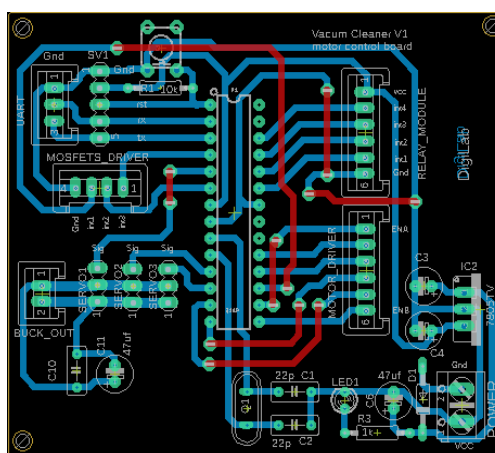

Figure 16. AVR_vacuum_board

2.3 Control and software design:

Control software serves as the backbone of robotic systems, orchestrating their actions, processing sensor data, and making real-time decisions. It is the unseen force driving the operation of robotic platforms, guiding them through complex environments and enabling them to accomplish diverse tasks with precision and efficiency. Cleaning cycles are made by programming and coding Arduino Mega which is microcontroller embedded in software and hardware. wireless protocols are used such as Wi-Fi or Bluetooth that enable communication between the robot and the user in easy and simple way.

2.4 Multi-functional cleaner robots (MFCRs) software mechanism

- The Arduino mega only has one processor, this limits how the software will be formed.
- Both the stepper motor and the ultrasonic sensor need the program to stop a few milli seconds for the parts to work correctly. This means that motor and the sensor cannot run together.
- Therefore, the program needs to run the stepper motors and periodically turn on the sensors to detect if there is any obstacles or stairs in its way

- In figure17 the flow chart shows multifunctional cleaner robot operation
- C++ is a programming language used on the Arduino mega microcontroller. It is used to read sensor data, control the motors, and communicate with arduino mega through serial communication
- Precision Cleaning with Edge Detection:

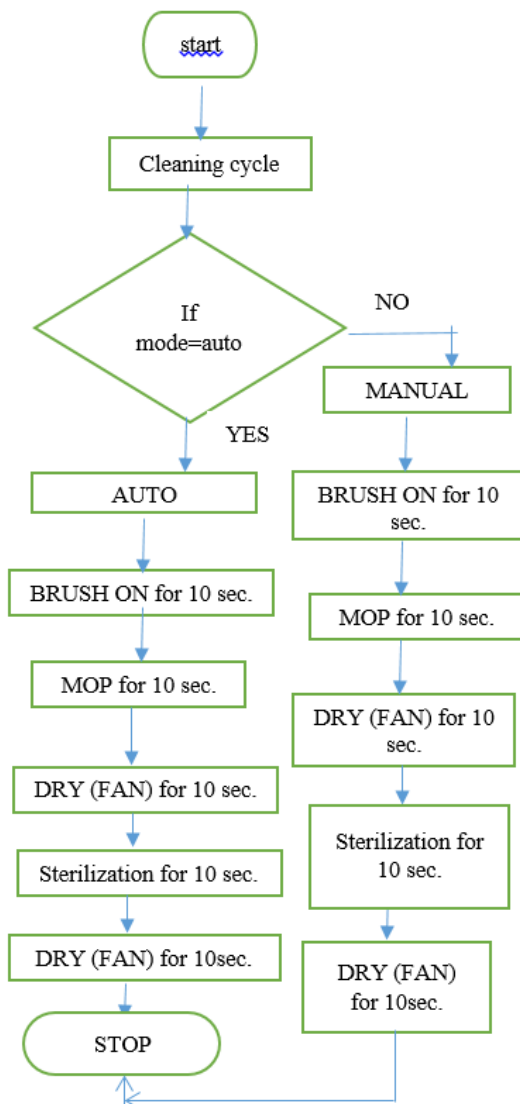

Figure17. The flow chart of multifunctional cleaner robot operation

With boast edge detection sensors that enable robotic cleaner to detect walls, baseboards, and furniture edges. These sensors ensure that the robot can effectively clean along edges and in tight spaces where dirt and debris tend to accumulate. By combining this technology with smart navigation, the robotic vacuum cleaner can reach every nook and cranny, leaving your floors spotless

- In figure 18, the flow chart shows what happens if the robot vacuum cleaner detects an obstacle or stairs.

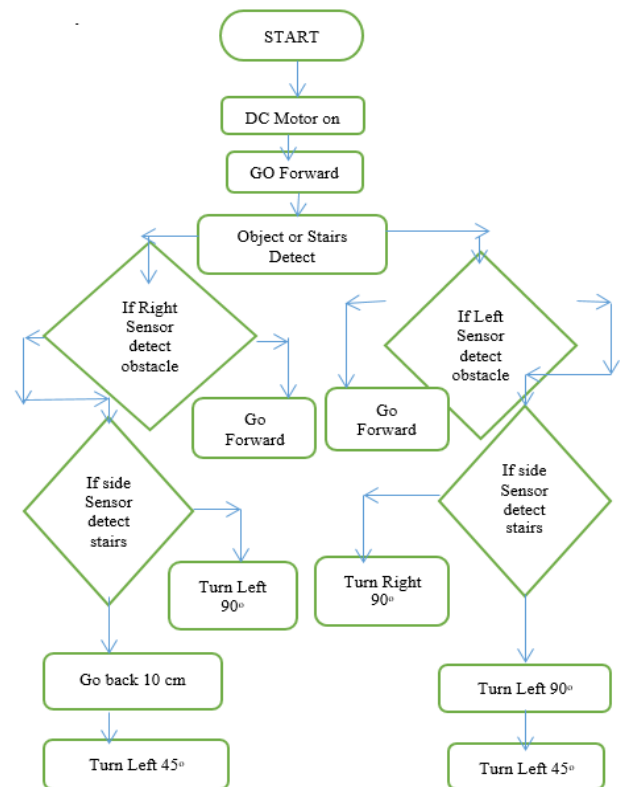

Figure 18. The flow chart shows what happens if the robot vacuum cleaner detects an obstacle or stairs

3. CONCLUSION

The developing a multi-functional cleaner robot is a complex project that involves a range of skills, including mechanical engineering, software development, and product design. It's important to approach the project with a clear plan and be prepared to iterate and improve upon your initial designs. The cleaner robot developed in this project showcases the potential of integrating multiple functionalities into a single device. However, there are several areas for potential improvement and expansion. Future work on this project could focus on these enhancements. Designing a system for autonomous navigation, refining the cleaning algorithm, and upgrading the hardware would collectively create a more robust and appealing product for consumers

The experience gained from this project has been invaluable, providing insights into real-world applications and the complexities of designing and implementing a functional robotic system. It serves as a foundation for further innovation and development in the field of robotic cleaners.

This robot exhibits remarkable versatility by incorporating various cleaning mechanisms. It employs rotating brushes and suction mechanisms for efficient floor cleaning, including sweeping, vacuuming, and mopping functions. Additionally, it incorporates specialized attachments and tools for tasks such as window cleaning, dusting, and even disinfection, making

it an all-in-one solution for comprehensive household maintenance

Acknowledgment:

I would like to express my sincere gratitude to **Dr. Hala B. Nafea** for their invaluable guidance, support, and encouragement throughout this research

I am also deeply thankful to **Dr. Hanan M. Amer** for her continuous assistance, constructive suggestions, and generous support.



References:

- Ajeil, F. H., Ibraheem, I. K., Azar, A. T., & Humaidi, A. J. (2020). Autonomous navigation and obstacle avoidance of an omnidirectional mobile robot using swarm optimization and sensors deployment. *International Journal of Advanced Robotic Systems*, 17(3), 1729881420929498.
- Bisht, R. S., Pathak, P. M., & Panigrahi, S. K. (2022). Design and development of a glass façade cleaning robot. *Mechanism and Machine Theory*, 168, 104585.
- Boyce, J. M. (2016). Modern technologies for improving cleaning and disinfection of environmental surfaces in hospitals. *Antimicrobial Resistance & Infection Control*, 5(1), 10.
- Butaney, S., Gaurav, K., Ranjan, P., & Shrivastava, N. V. (2025). Recent developments in autonomous floor-cleaning robots: a review. *Industrial Robot: the international journal of robotics research and application*, 52(3), 362-380.
- Chang, C. L., Chang, C. Y., Tang, Z. Y., & Chen, S. T. (2018). High-efficiency automatic recharging mechanism for cleaning robot using multi-sensor. *Sensors*, 18(11), 3911.
- Ivanov, S. H., & Webster, C. (2017, October). Designing robot-friendly hospitality facilities. In *Proceedings of the scientific conference "Tourism. Innovations. Strategies"* (pp. 13-14).
- Junior, L. C. L., de Pina Filho, A. C., & de Pina, A. C. (2014). A Study for Cleaner Pool Robot Design. In *ABCAM Symposium Series in Mechatronics* (Vol. 6, pp. 661-670).
- Khaleel, H. Z., & Oleiwi, B. K. (2024). Design and Implementation Low Cost Smart Cleaner Mobile Robot in Complex Environment. *Mathematical Modelling of Engineering Problems*, 11(10).
- Kim, J., Mishra, A. K., Limosani, R., Scafuro, M., Cauli, N., Santos-Victor, J., ... & Cavallo, F. (2019). Control strategies for cleaning robots in domestic applications: A comprehensive review. *International Journal of Advanced Robotic Systems*, 16(4), 1729881419857432.
- Moon, W., Park, B., Nengroo, S. H., Kim, T., & Har, D. (2022, November). Path planning of cleaning robot with reinforcement learning. In *2022 IEEE International Symposium on Robotic and Sensors Environments (ROSE)* (pp. 1-7). IEEE.
- Murdan, A. P., & Ramkissoon, P. K. (2020, November). A smart autonomous floor cleaner with an Android-based controller. In *2020 3rd International Conference on Emerging Trends in Electrical, Electronic and Communications Engineering (ELECOM)* (pp. 235-239). IEEE.
- Pathmakumar, T., Kalimuthu, M., Elara, M. R., & Ramalingam, B. (2021). An autonomous robot-aided auditing scheme for floor cleaning. *Sensors*, 21(13), 4332.
- Prassler, E., Ritter, A., Schaeffer, C., & Fiorini, P. (2000). A short history of cleaning robots. *Autonomous Robots*, 9(3), 211-226.
- Prassler, E., Ritter, A., Schaeffer, C., & Fiorini, P. (2000). A short history of cleaning robots. *Autonomous Robots*, 9(3), 211-226.
- Said, A. I., Yusri, A. R., Damanik, T. S. A., Prabaswari, A. D., & Sofi, N. (2024). Redesign of Automatic Vacuum Cleaner with Participatory Approach. In *SHS Web of Conferences* (Vol. 189, p. 01004). EDP Sciences.
- Sinnapatchai, D., Zaini, N. E. M. I. M., & Som, M. M. (2022). Cleaning robot with android application controller. *Multidisciplinary Applied Research and Innovation*, 3(2), 354-361.
- Soni, K. (2017). Autonomous smart floor cleaning robot (CLEANER). In *VIMPACT—2017 Conference Proceedings & Int. J. Eng. Res. Technol. (IJERT)* (Vol. 5, No. 23, pp. 1-4).
- Vasic, M., & Billard, A. (2013, May). Safety issues in human-robot interactions. In *2013 IEEE International Conference on Robotics and Automation* (pp. 197-204). IEEE.
- Wang, Y., Hong, X., Ma, Z., Ma, T., Qin, B., & Su, Z. (2023). Towards practical multi-robot hybrid tasks allocation for autonomous cleaning. *arXiv preprint arXiv:2303.06531*.
- Yan, Z., Schreiberhuber, S., Halmetschlager, G., Duckett, T., Vincze, M., & Bellotto, N. (2020). Robot perception of static and dynamic objects with an autonomous floor scrubber. *Intelligent Service Robotics*, 13(3), 403-417.
- Yatmono, S., Khairudin, M., Pramono, H. S., & Asmara, A. (2019, November). Development of intelligent floor cleaning robot. In *Journal of Physics: Conference Series* (Vol. 1413, No. 1, p. 012014). IOP Publishing.
- Zhao, Z., Chen, W., Peter, C. C., & Wu, X. (2016, December). A novel navigation system for indoor cleaning robot. In *2016 IEEE International Conference on Robotics and Biomimetics (ROBIO)* (pp. 2159-2164). IEEE.

Ahmed A. Abdeltwab

Department of Mechatronics
Engineering, Faculty of
Engineering, Mansoura University,
Mansoura, Egypt
hihamadaali2001@gmail.com

Hanan M. Amer

Department of Electronics and
Communications Engineering,
Faculty of Engineering, Mansoura
University, Mansoura, Egypt
eng_hanan_2007@mans.edu.eg
ORCID: 0000-0001-5872-4376

Hala B. Nafea

Department of Electronics and
Communications Engineering,
Faculty of Engineering, Mansoura
University, Mansoura, Egypt
halabahyeldeen@mans.edu.eg
ORCID: 0000-0002-4522-0889
